

MODEL HDS-215

HEAVY DUTY

SEMI-AUTOMATIC COMBINATION SHRINK SYSTEM

HEAVY DUTY CONSTRUCTION
THROUGHOUT

STANDARD IMPULSE SEAL WITH
OPTIONAL HOT KNIFE

UL LISTED CONTROL PANEL



OUR MOST POPULAR, DEPENDABLE, MULTI-USE SHRINK SYSTEM

FEATURES

Control Panel

- Top Mounted, Easy Access, UL Listed Control Panel
- RS-3 Digital Controller For Easy System Setup and Operation with Built In Diagnostics and Alarms
- Single Cord 220V power supply

Sealing Area

- Large, 15" W by 20" L Sealing Area
- Cast Aluminum Seal Head with Film Clamps
- Dual Magnets with Adjustable Dwell Time
- Posi-Trac Power Take Away Conveyor
- Smooth Product Transfer from Power Take Away to Tunnel with Single Hand Crank Height Adjustment

Shrink Tunnel

- 8" H By 14½" W Tunnel Opening
- Adjustable Heat Tunnel Conveyor Belt for Bottom Shrink Control
- Package Centering Adjustment Conveyor Alignment System for Even Shrink
- Automatic Cool Down

Other Features

- *RAPIDHS* - Standard Machine Options will Ship in 5 Days or Less
- Two Year Warranty
- Three Individually Adjustable Perforating Wheels
- Adjustable Film Cradle
- Heavy Duty Casters and Levelers
- Stainless Steel Model Available

TWO YEAR WARRANTY

MODEL HDS-215

Machine Specifications

Film Capacity	20" Wide (51 cm)
L Bar Seal Area	15" W, 20" L (38 W, 51 L cm)
Inside Tunnel Dimensions	21" L, 14 1/2" W, 8" H (53 L, 37 W, 20 H cm)
Tunnel Conveyor Speed	0-20 Feet per Minute (0-6 meters per minute)
Overall Dimensions	76" L, 29" W, 57" H (193 L, 74 W, 145 H cm)
Working Height	37" (94 cm)
Power Requirements	220 Volts, 25 Amp Single Circuit with Ground
Wattage	Tunnel: 3,600 Watts Conveyor Belt: 500 Watts
Weight	625 lbs. (284 kg)

Machine Footprint

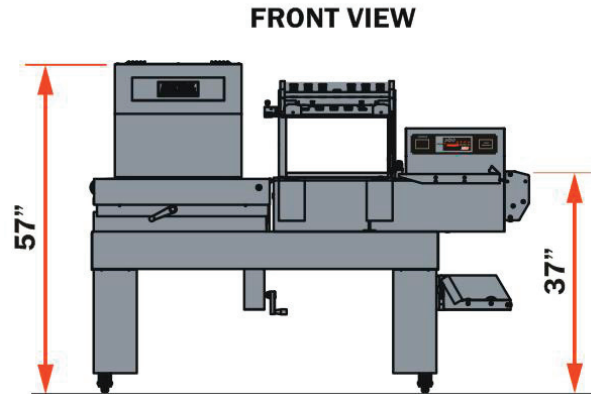
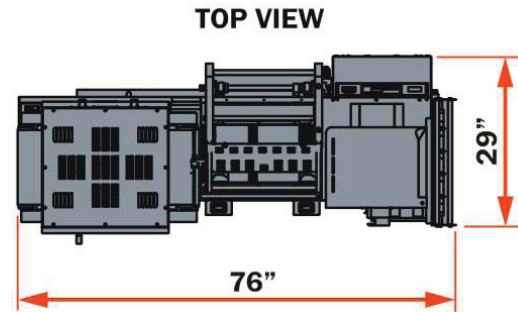

OPTIONS

- Hot Knife Seal System
- 15" W by 24" L Extended Sealing Area
- Powered Lift/Posi-Trac Power Take Away Conveyor
- Hot Hole Punch or Adjustable Hot Hole Punch with Articulated Arm
- Corrugated Loading Tray
- Left Hand Reverse Flow
- Stainless Steel Construction
- Spare Parts Kit
- Air Actuated Sealing Head
- 6 Inch Film Separator Rod
- Dual Film Rack
- Powered Film Unwind with Perforating Roller and 6 Inch High Adjustable Inverting Head
- GTC-90 and 180 Gravity Turn Around Conveyors
- Powered Accumulator Tables